

DE	Gebrauchsanleitung /Montageanleitung	2
FR	Mode d'emploi /Instructions de montage	3
EN	Instructions for use /assembly instructions	4
IT	Istruzioni per l'uso /Istruzioni per Installazione	5
ES	Modo de empleo /Instrucciones de montaje	6
NL	Gebruiksaanwijzing /Handleiding	7
DK	Brugsanvisning /Monteringsvejledning	8
PT	Instruções para uso /Manual de Instalação	9
PL	Instrukcja obsługi /Instrukcja montażu	10
CS	Návod k použití /Montážní návod	11
SK	Návod na použitie /Montážny návod	12
ZH	用户手册 /组装说明	13
RU	Руководство пользователя /Инструкция по монтажу	14
HU	Használati útmutató /Szerelési útmutató	15
FI	Käyttöohje /Asennusohje	16
SV	Bruksanvisning /Monteringsanvisning	17
LT	Vartotojo instrukcija /Montavimo instrukcijos	18
HR	Upute za uporabu /Uputstva za instalaciju	19
TR	Kullanım kılavuzu /Montaj kılavuzu	20
RO	Manual de utilizare /Instrucțiuni de montare	21
EL	Οδηγίες χρήσης /Οδηγία συναρμολόγησης	22
SL	Navodilo za uporabo /Navodila za montažo	23
ET	Kasutusjuhend /Paigaldusjuhend	24
LV	Lietošanas pamācība /Montāžas instrukcija	25
SR	Uputstvo za upotrebu /Uputstvo za montažu	26
NO	Bruksanvisning /Montasjeveiledning	27
BG	Инструкция за употреба /Ръководство за монтаж	28
SQ	Udhëzuesi i përdorimit /Udhëzime rreth montimit	29
AR	دليل الاستخدام /تعليمات التجميع	30

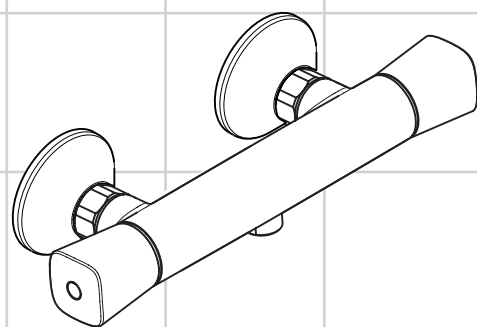

Ecostat Universal
13122000

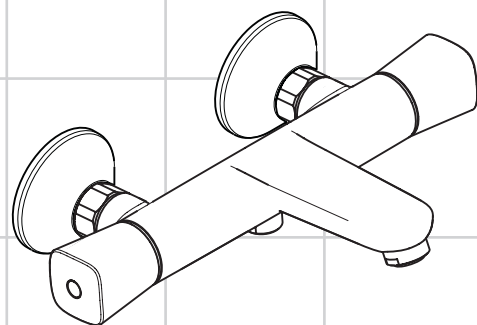

Ecostat Universal
13123000



Указания по технике безопасности

- Во время монтажа следует надеть перчатки во избежание прищемления и порезов.
- Изделие разрешается использовать только в гигиенических целях: для принятия ванны и личной гигиены.
- Дети, а также взрослые с физическими, умственными и/или сенсорными недостатками должны пользоваться изделием только под присмотром. Запрещается пользоваться изделием в состоянии алкогольного или наркотического опьянения.
- донного клапа. Перед установкой смесителя необходимо регулировочными кранами выровнять давление холодной и горячей воды при помощи вентилей регулирующих подачу воды в квартиру.

Указания по монтажу

- Перед монтажом следует проверить изделие на предмет повреждений при перевозке. После монтажа претензии о возмещении ущерба за повреждения при перевозке или повреждения поверхностей не принимаются.
- Трубы и арматура должны быть установлены, промыты и проверены в соответствии с действующими нормами.
- Необходимо соблюдать требования по монтажу, действующие в соответствующих странах.
- Изделие не предназначено для использования в паровой бане!

Термостат с проточными нагревателями

- При подключении ручного душа, из него необходимо удалить возможно установленный в нем дроссель.
- При неполадках проточного нагревателя или значительных перепадах давления в подвод холодной воды следует установить дроссель, входящий в комплект (арт. № 97510000).
- Термостат душ: В сочетании с проточными нагревателями упорный диск ECOSTOP (№ арт. #98916000) следует насаживать, повернув его на 180° в осевом направлении.

Технические данные

Рабочее давление:	не более. 1 МПа
Рекомендуемое рабочее давление:	0,1 - 0,5 МПа
Давление:	1,6 МПа
(1 МПа = 10 bar = 147 PSI)	
Температура горячей воды:	не более. 80°С
Рекомендуемая темп. гор. воды:	65°С
Термическая дезинфекция:	не более. 70°С / 4 мин
Размеры подключения:	150 ± 12 mm
Подключение G 1/2:	холодная справа - горячая слева

укомплектован клапаном обратного тока воды

Изделие предназначено исключительно для питьевой воды!

Неисправность	Причина	Устранение неисправности
недостаточный давление (если устан напор воды)	- Проблемы водоснабжения	- Проверить овлен насос проверить работу насоса
	- Грязеулавливающие сита загрязнены (#96922000)	- Очистите грязеулавливающие сита перед термостатом и на регуляторе (#96922000)
	- Фильтр душа загрязнен	- Очистить фильтр
Подмес воды, в закрытом положене горячая вода стремится в подводку холодной воды или наоборот	- Клапан обратного тока воды загрязнен или неисправен	- Очистить кланан или заменить при необходимости
	- Термостат не настроен	- Настроить термостат
Температура смешанной воды не соответствует шкале	- Температура горячей воды слишком низкая	- Поднять температуру горячей воды с 42 град.С до 65 град.С
	- Регулятор засорен накипью	- Замените регулятор
Из душа или выхода капает вода	- Загрязнения или отложения на уплотнительном кольце, верхняя часть запора повреждена	- Очистите или замените верхнюю часть отключающего устройства
	- Упорный диск Ecoston не повернут на 180° в осевом направлении (#98916000)	- Ecoston Поверните осевой диск (#98916000) на 180° в осевом направлении
Проточный нагреватель не включается в режиме работы термостата	- Дроссель не удален из ручного душа	- Извлеките дроссель из ручного душа
	- Грязеулавливающие сита загрязнены	- Очистите / замените грязеулавливающие сита
	- Клапан обратного тока заедает	- Замените клапаны обратного течения

Описание символов



Не применяйте силикон, содержащий уксусную кислоту.

max.
≈ 42°С

Safety Function (см. стр. 32)

С помощью функции Safety Function может быть задана максимальная температура воды, например 42°С.



Настройка (см. стр. 32)

После монтажа следует проверить температуру на выходе из термостата. Скорректируйте температуру воды, если она отличается от установленной на термостате.

ECO
≈ 10 l

ECOSTOP (см. стр. 33)



Техническое обслуживание (см. стр. 33)

- Для гарантии плавного изменения температуры и долгого срока службы необходимо периодически поворачивать ручку регулировки температуры из положение максимально горячая в положение максимально холодная вода.
- Термостат оснащен клапанами обратного течения. Защита обратного тока должна регулярно проверяться (минимум один раз в год) по стандарту DIN EN 1717 или в соответствии с национальными или региональными нормативами



Эксплуатация (см. стр. 34)



Размеры (см. стр. 35)



Схема потока (см. стр. 35)



Комплект (см. стр. 36)



Очистка

см прилагаемая брошюра



Знак технического контроля (см. стр. 36)



Монтаж см. стр. 31

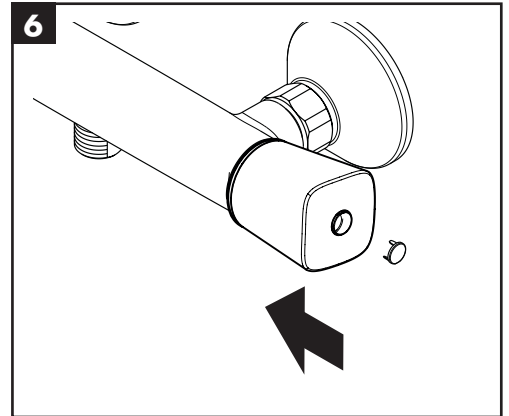
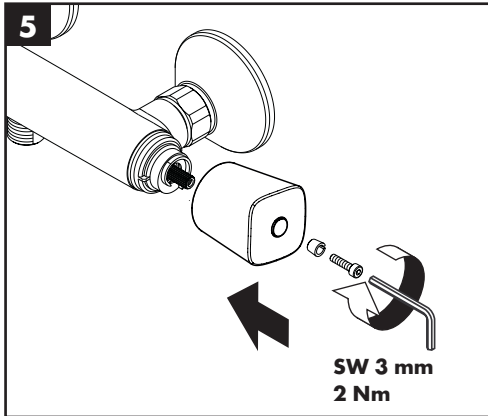
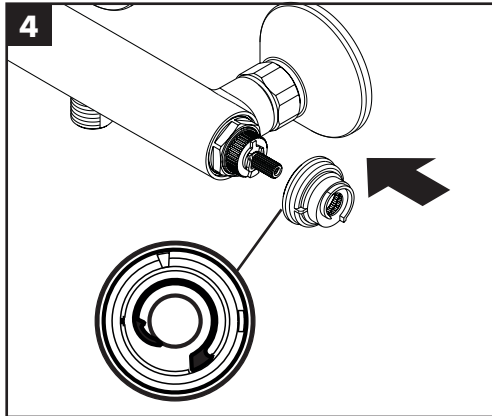
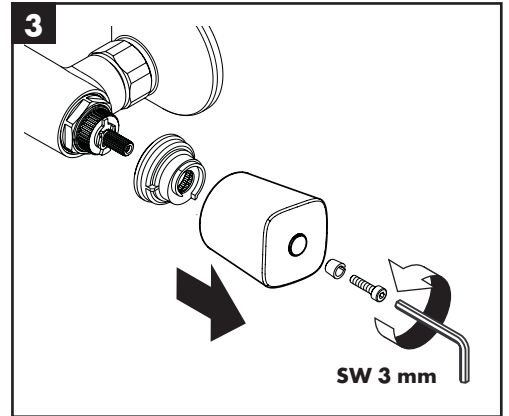
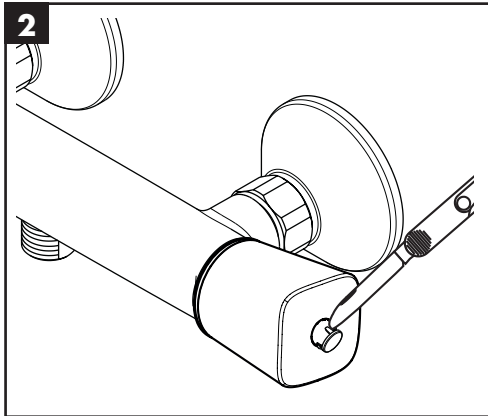
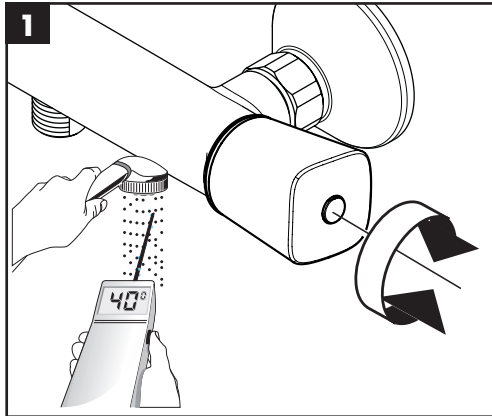

max.
≈ 42 °C

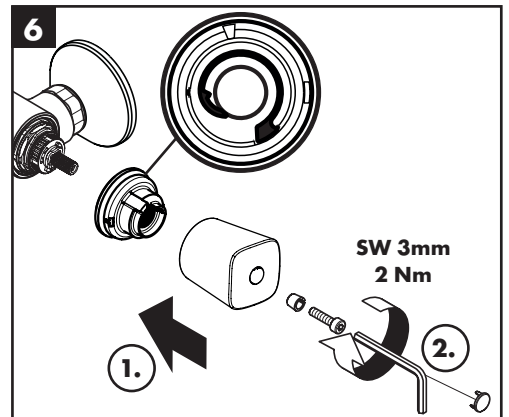
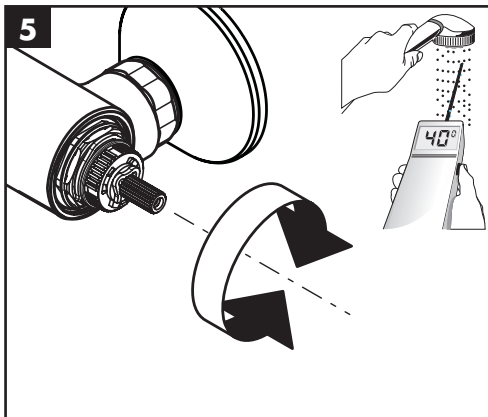
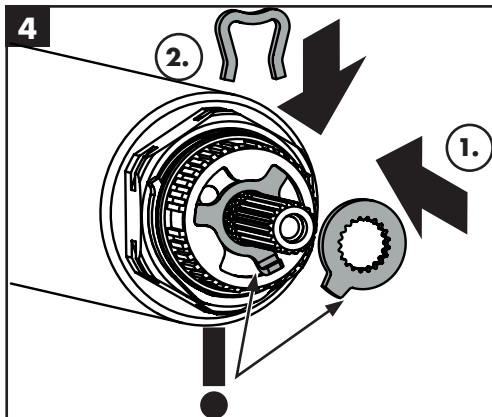
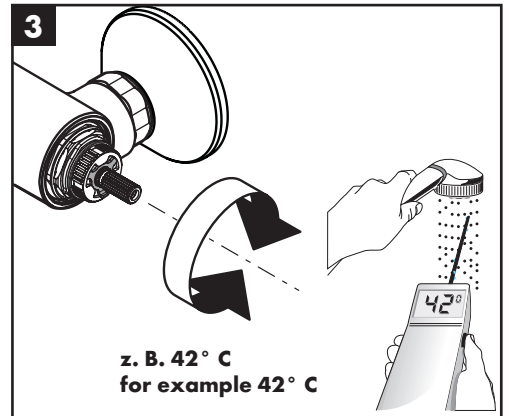
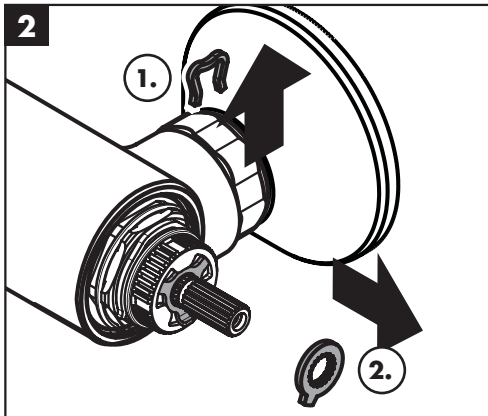
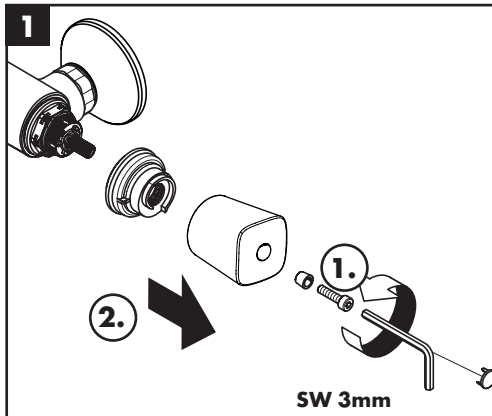

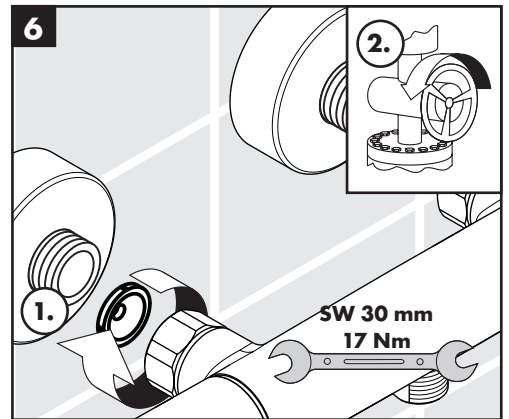
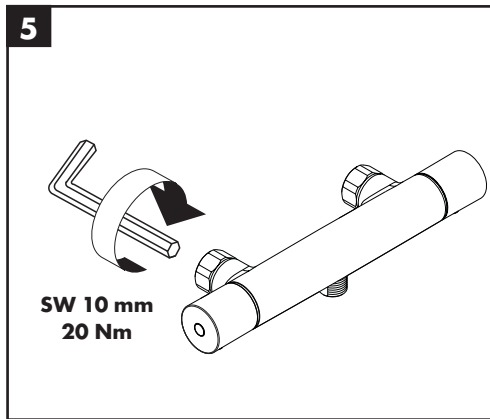
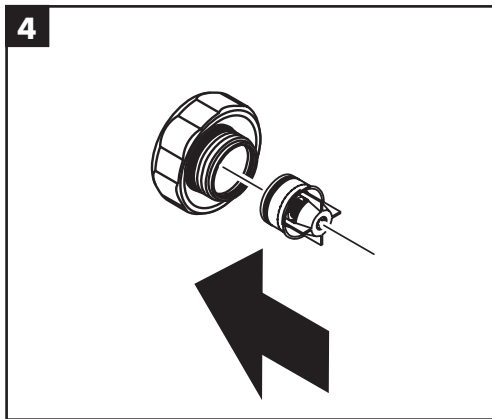
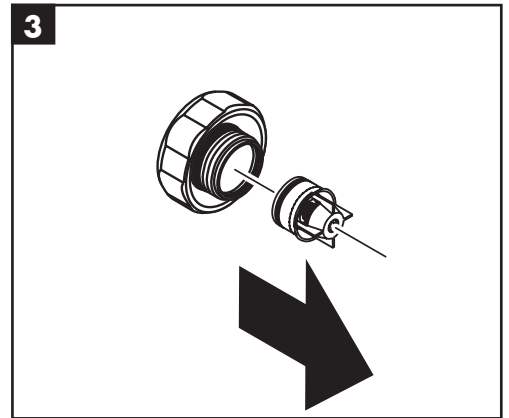
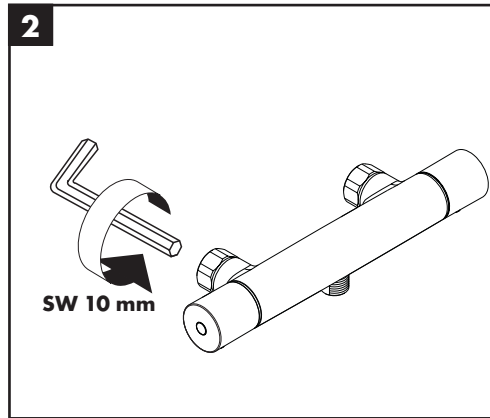
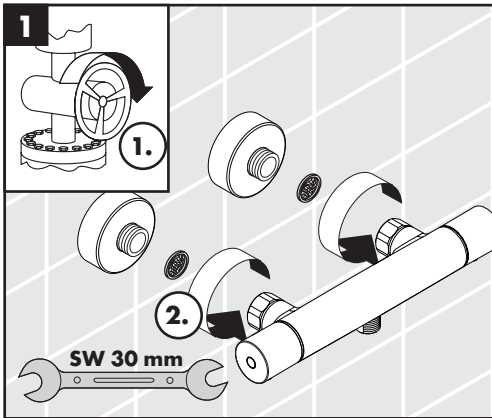
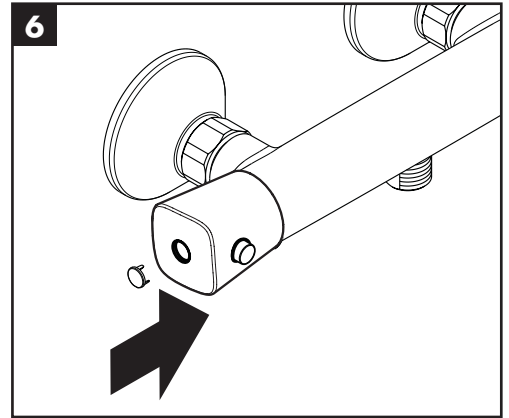
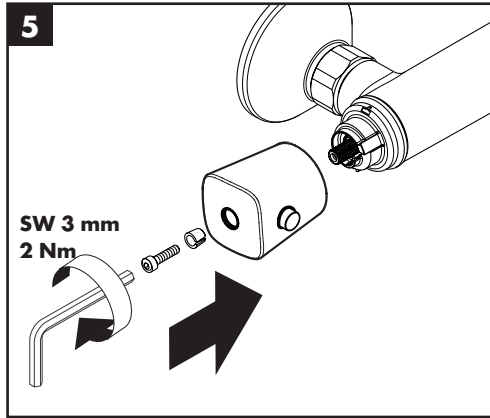
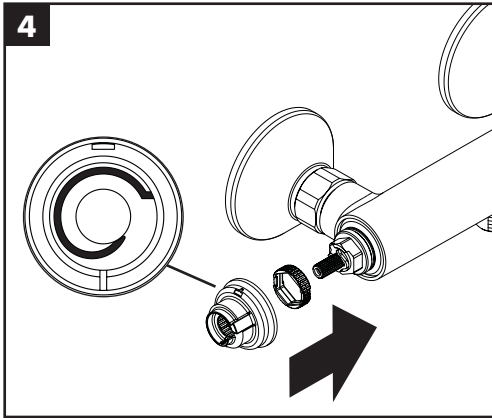
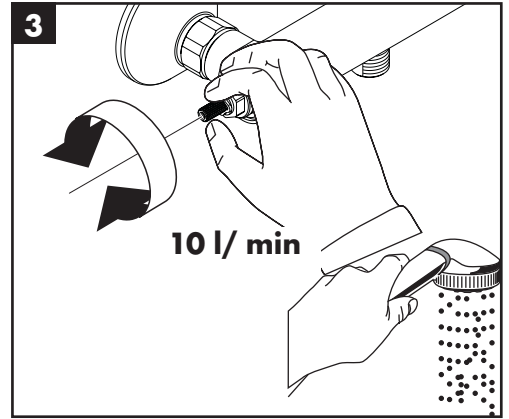
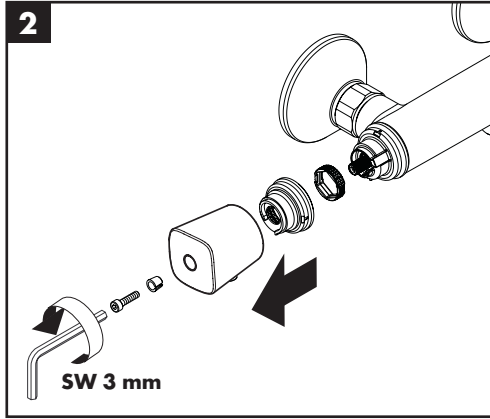
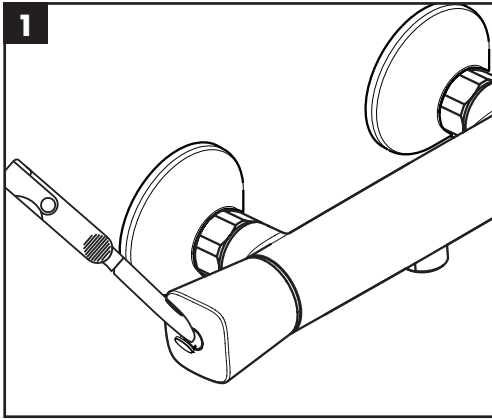

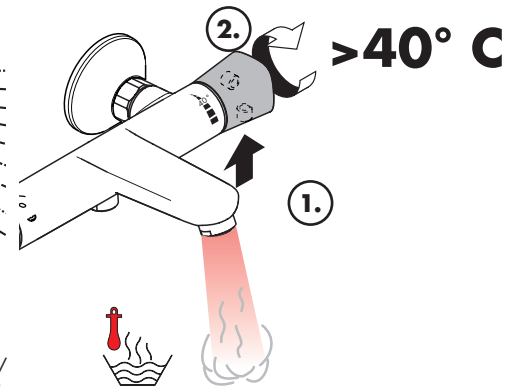
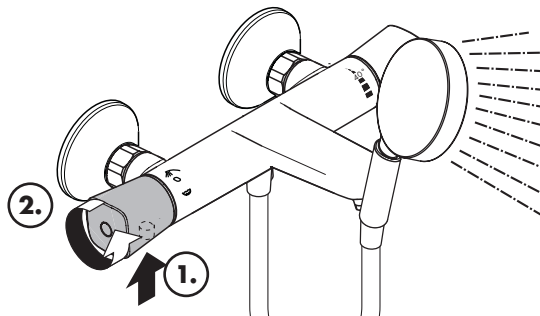
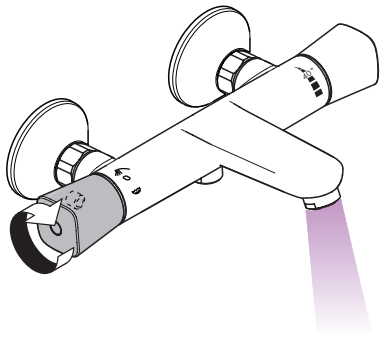

öffnen / ouvert / open / aperto / abierto / open / åbne / abrir / otworzyć / otevřít / otvorit / 开 / открыть / nyitás / avaamine / öppna / atidaryti / Otvaranje / açmak / deschide / ανοικτό / odpreti / avage / atvērt / otvoriti / árne / отварање / hare / فتح

warm / chaud / hot / caldo / caliente / warm / varmt / quente / ciepła / teplá / teplá / 热 / горячая / meleg / lämmin / varmt / karštas / Vruća voda / sıcak / cald / ζεστό / toplo / kuum / karsts / topla / varm / топло / i ngrohtë / سخن

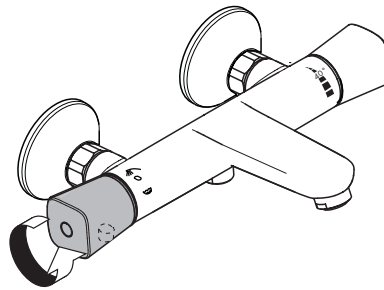
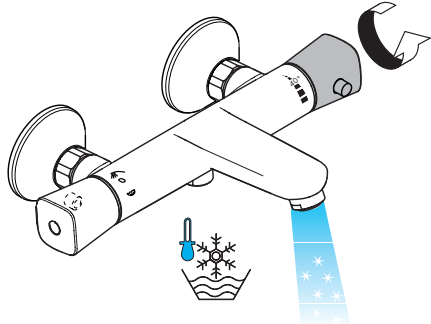

kalt / froid / cold / freddo / frío / koud / koldt / fria / zimna / studená / studená / 冷 / холодная / hideg / kylmä / kallt / šaltas / Hladno / soğuk / reze / κρύο / mrzlo / külm / auksts / hladno / kaldt / студено / i ftohtë / بارد

schließen / fermé / close / chiudere / cerrar / sluiten / lukke / fechar / zamknąć / zavřít / uzavriť / 关 / закрыть / bezárás / sulkeminen / stänga / uždaryti / Zatvaranje / kapatmak / închide / κλειστό / zapreti / sulgege / aizvērt / zatvori / lukke / затварање / mbylle / إغلاق

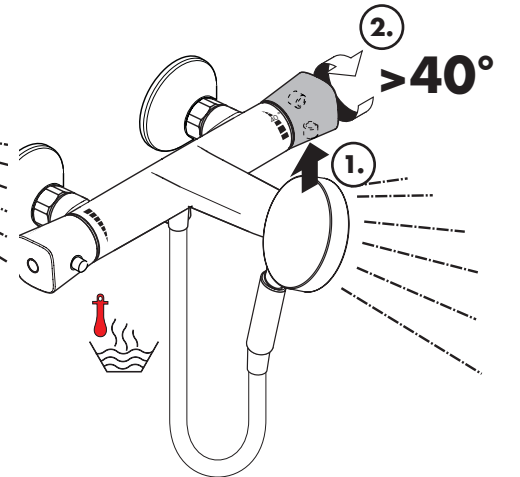
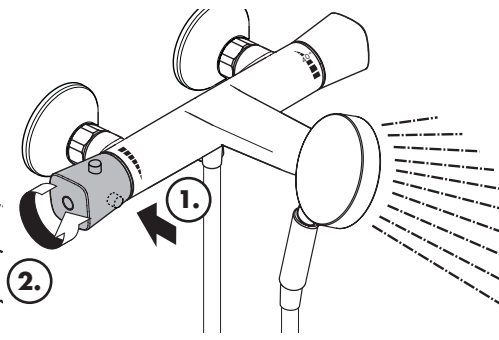
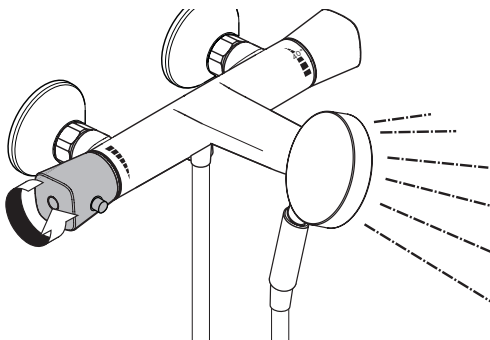

öffnen / ouvert / open / aperto / abierto / open / åbne / abrir / otworzyć / otevřít / otvorit / 开 / открыть / nyitás / avaamine / öppna / atidaryti / Otvaranje / açmak / deschide / ανοικτό / odpreti / avage / atvērt / otvoriti / árne / отварање / hare / فتح

warm / chaud / hot / caldo / caliente / warm / varmt / quente / ciepła / teplá / teplá / 热 / горячая / meleg / lämmin / varmt / karštas / Vruća voda / sıcak / cald / ζεστό / toplo / kuum / karsts / topla / varm / топло / i ngrohtë / سخن

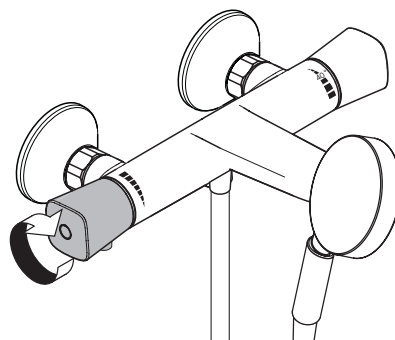
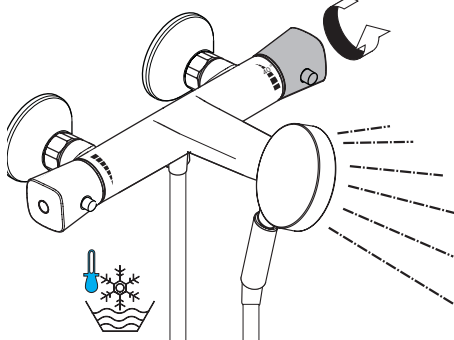

kalt / froid / cold / freddo / frío / koud / koldt / fria / zimna / studená / studená / 冷 / холодная / hideg / kylmä / kallt / šaltas / Hladno / soğuk / reze / κρύο / mrzlo / külm / auksts / hladno / kaldt / студено / i ftohtë / بارد

schließen / fermé / close / chiudere / cerrar / sluiten / lukke / fechar / zamknąć / zavřít / uzavriť / 关 / закрыть / bezárás / sulkeminen / stänga / uždaryti / Zatvaranje / kapatmak / închide / κλειστό / zapreti / sulgege / aizvērt / zatvori / lukke / затварање / mbylle / إغلاق

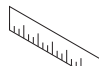

EcoStat Universal
13123000

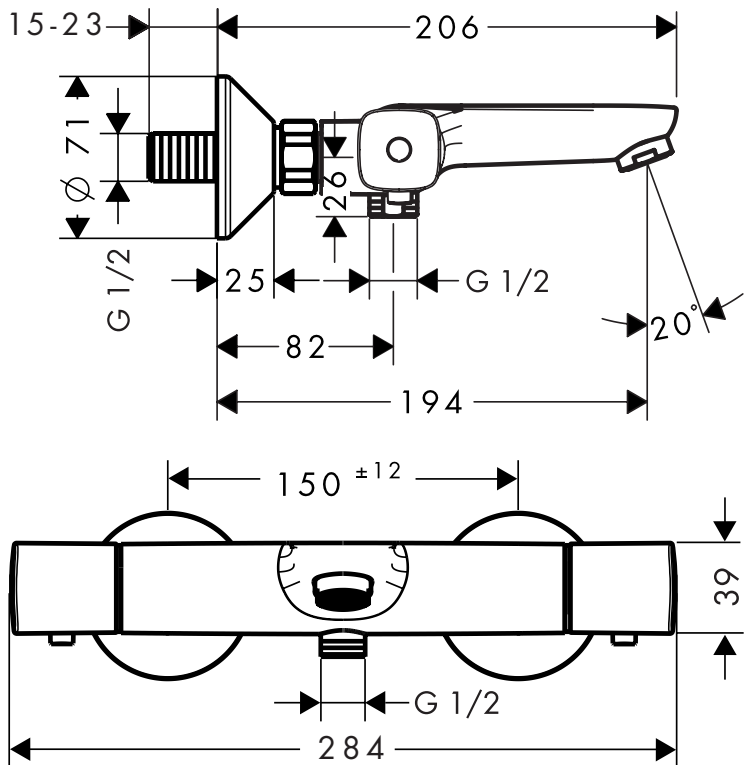

EcoStat Universal
13122000

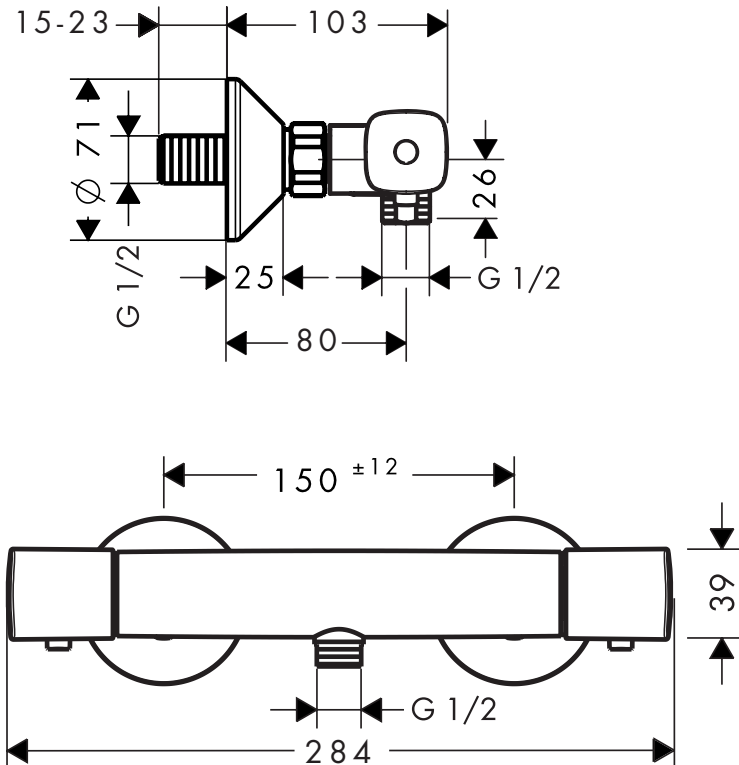

EcoStat Universal
13123000

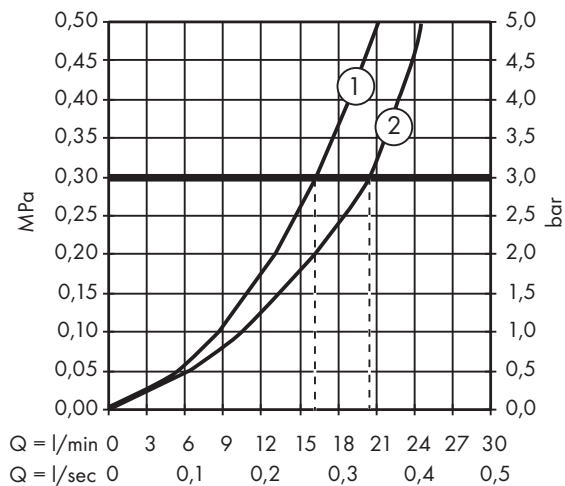

EcoStat Universal
13122000

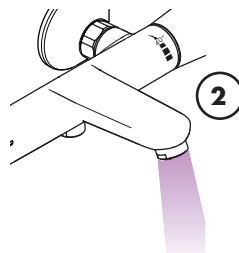
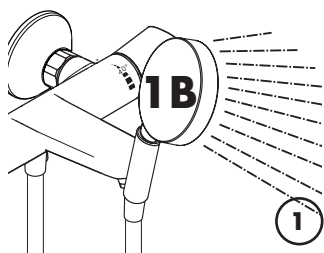
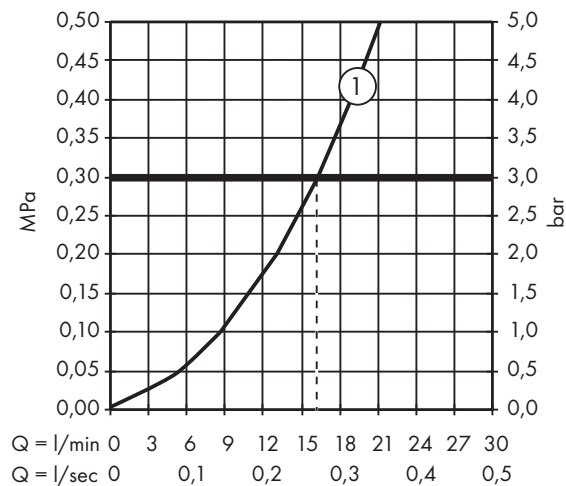



Ecostat Universal
13122000

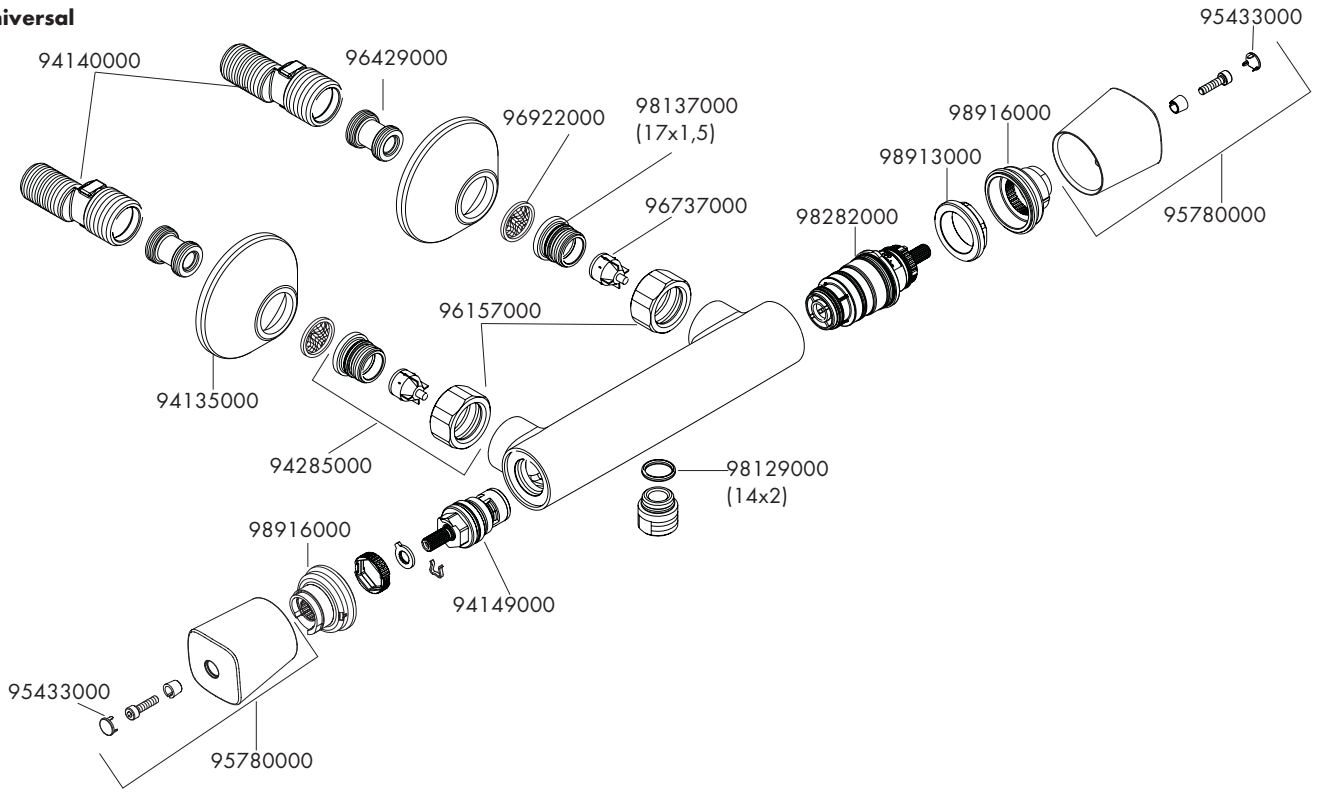

Ecostat Universal
13123000

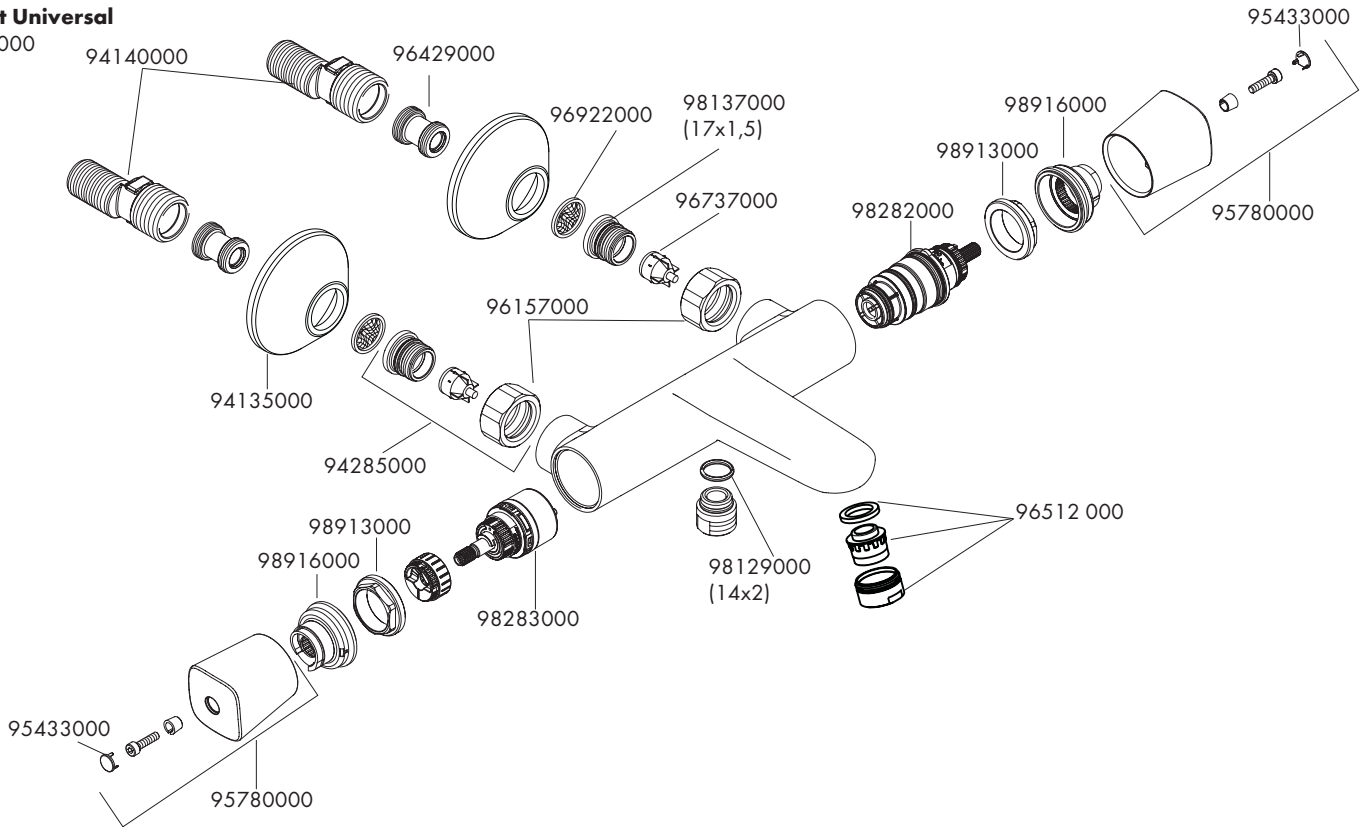

	P-IX	DVGW	SVGW	ACS	WRAS	ETA	NF
13122000				X	X		
13123000				X	X		



On the following pages 37 - 40 you can find important information only for the installation in UK

Safety and Important Information

Hansgrohe products are safe provided they are installed, used and maintained in accordance with these instructions and recommendations.

Please read these instructions thoroughly and retain for future use.

The plumbing installation of this thermostat mixing valve must comply with the requirements of UK

Water Regulations/Bylaws (Scotland), Building Regulations or any other regulations specified by the local Water Authority and supplier.

The installation of thermostatic mixing valves must comply with the requirements of the Water Supply (Water Fittings) Regulations 1999.

We strongly recommend that you use a plumber registered with or a member of an Association:

Chartered Institute of Plumbing and Heating Engineering (CIPHE)
Water Industry Approved Plumber Scheme (WIAPS)

Dispose of plastic bags carefully

Keep children well away from the work area.

Check for hidden pipes and cables in the wall before drilling holes.

The unit must be mounted on a finished waterproofed wall surface (usually tiles).

If you are using power tools (e.g. to drill holes) wear safety glasses and always disconnect tools from the power supply after use.

Do not operate the shower unit if the hand shower or spray hose has been damaged or is blocked.

Do not block the flow of water from the hand shower, by placing it on your hand or any other part of your body or foreign object.

The valve must remain accessible to maintain and commission it.

The thermostatic unit should be serviced annually by a qualified person to ensure maximum safety during use.

The mixer is fitted with check valves (page 36 pos. 96737000). There are filters on the thermostatic element too (page 36 pos. 98282000).

The fitting of isolation valves is required (preferred location page 38 Installation Requirements)

Technical Data

This thermostatic valve will suit supplies of:
HIGH PRESSURE (HP-S)

Operating pressure:	max. 10 bar
Recommended operating pressure:	1 - 5 bar
Test pressure:	16 bar
Hot water temperature:	max. 80 °C
Recommended hot water temp.:	65 °C
Rate of flow from bath spout:	20 l/min. @ 3 bar
Rate of flow from shower outlet:	18 l/min. @ 3 bar
Maximum outlet temperature:	43 °C +/-*
Safety check:	40 °C
Hot water connection:	Left hand
Cold water connection:	Right hand
Minimum difference between hot water and mixed water temperature:	6 K
Hot and cold supply pressure should be balanced	

Mixed water temperature

Application	Mixed water temperature (at point of discharge)
Shower	41 °C max.
Washbasin	41 °C max.
Bath (44 °C fill)	44 °C max.
Bath (46 °C fill)	46 °C max.

Note: The maximum mixed water setting for the bath shower mixer must be 41 °C to ensure that the shower function does not exceed the recommended temperature.

* For preset outlet temperature adjustment – See page 32.

Recommended outlet temperatures

The BuildCert TMV scheme recommends the following set maximum mixed water outlet temperatures for use in all premises:

- 44 °C for bath fill but see notes below;
- 41 °C for showers;
- 41 °C for washbasins.

The mixed water temperatures must never exceed 46 °C.

The maximum mixed water temperature can be 2 °C above the recommended maximum set outlet temperatures.

Note: 46 °C is the maximum mixed water temperature from the bath tap. The maximum temperature takes account of the allowable temperature tolerances inherent in thermostatic mixing valves and temperature losses in metal baths.

It is not a safe bathing temperature for adults or children.

The British Burns Association recommends 37 to 37.5 °C as a comfortable bathing temperature for children. In premises covered by the Care Standards Act 2000, the maximum mixed water outlet temperature is 43 °C

Supply Conditions TMV2

Operating pressure range	High pressure
Maximum static pressure - bar	10
Flow pressure, hot and cold - bar	0.5 to 5
Hot supply temperature - °C	55 to 65
Cold supply temperature - °C	5 to 25

Valves operating outside these conditions of use cannot be guaranteed to operate as Type 2 valve.

Supply Conditions TMV3

Operating pressure range	High pressure	Low pressure
Maximum static pressure - bar	10	10
Flow pressure, hot and cold - bar	1 to 5	0.2 to 1
Hot supply temperature - °C	52 to 65	52 to 65
Cold supply temperature - °C	5 to 20	5 to 20

Installation Requirements

This thermostatic mixer valve must be installed in compliance with current Water Regulations. If you have any doubts about the Water Regulation requirements contact your local water services provider or use the services of a professional plumber.

The thermostatic mixing valve must be installed in a position that is easily accessible for commissioning and future servicing.

This mixer valve is suitable for use with the following water supply systems:

- Gas Combination Boiler (multi-point) 1.0 - 10 bar*
- Unvented System (pressure balanced) 1.0 - 10 bar
- Pumped System 1.0 - 10 bar

IMPORTANT: If you install this mixer with a gravity fed system, there must be a minimum head (vertical distance) from the underside of the cold water storage tank to the showerhead position of at least 5 metre.

Before connecting the mixer, water should be flushed through the system to remove all debris that might otherwise damage the valve.

* If pressure is in excess of 3.5 bar, a pressure-reducing valve should be fitted.

Requirement for valve accessibility to maintain and commission the valve.

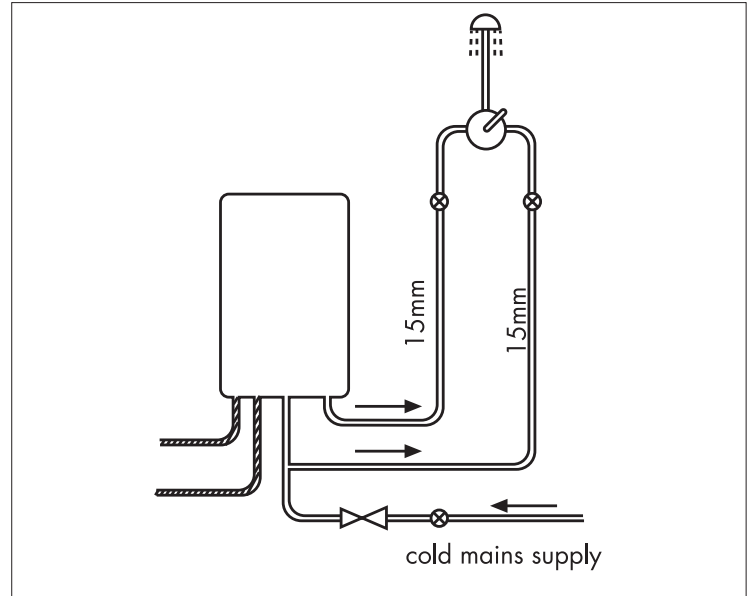

Gas Combination Boiler (multi-point)

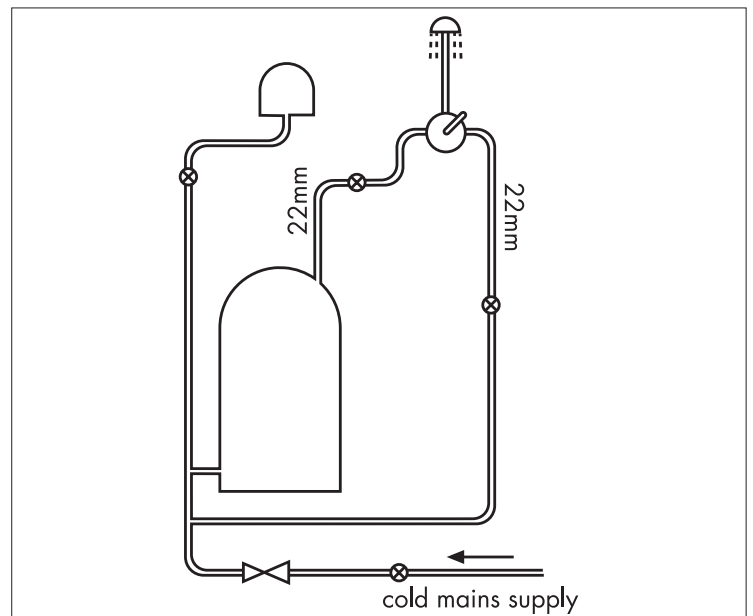

Unvented System (pressure balanced)

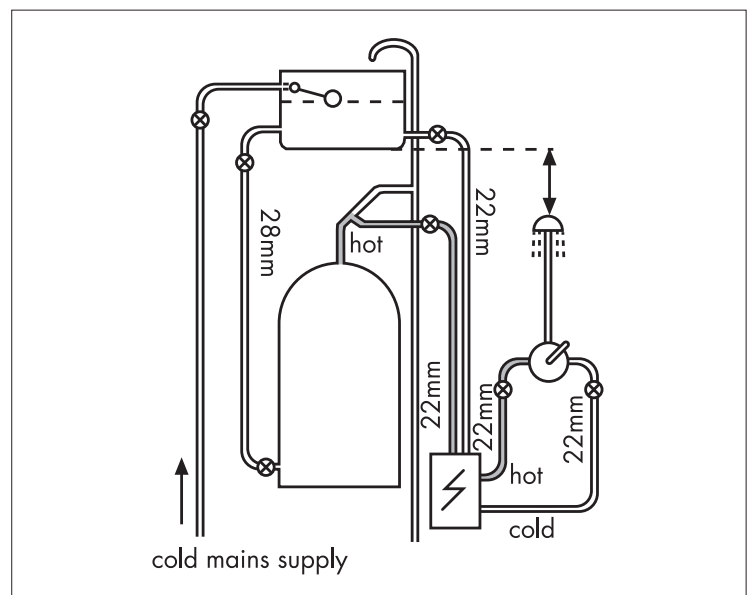

Pumped System

KEY



Isolating valve



Reducing valve



Mixer Valve



Pump

Commissioning and in-service tests

Commissioning

Purpose

Since the installed supply conditions are likely to be different from those applied in the laboratory tests it is appropriate, at commissioning, to carry out some simple checks and tests on each mixing valve to provide a performance reference point for future in-service tests.

Procedure

1. Check that:
 - a) the designation of the thermostatic mixing valve matches the intended application
 - b) the supply pressures are within the range of operating pressures for the designation of the valve
 - c) the supply temperatures are within the range permitted for the valve and by guidance information on the prevention of legionella etc.
2. Adjust the temperature of the mixed water in accordance with the manufacturer's instructions (page 32) and the requirement of the application and then carry out the following sequence:
 - a) record the temperature of the hot and cold water supplies
 - b) record the temperature of the mixed water at the largest draw-off flow rate
 - c) record the temperature of the mixed water at a smaller draw-off flow rate, which shall be measured
 - d) isolate the cold water supply to the mixing valve and monitor the mixed water temperature
 - e) record the maximum temperature achieved as a result of (d) and the final stabilised temperature

NOTE: The final stabilised mixed water temperature should not exceed the values in Table A.

- f) record the equipment, thermometer etc. used for the measurements

Table A: Guide to maximum stabilised temperatures recorded during site tests

Application	Mixed water temperature
Shower	43 °C
Washbasin	43 °C
Bath (44 °C fill)	46 °C
Bath (46 °C fill)	48 °C

The mixed water temperature at terminal fitting should never exceed 46°C.

If there is a residual flow during the commissioning or the annual verification (cold water supply isolation test), then this is acceptable providing the temperature of the water seeping from the valve is no more than 2°C above the designated maximum mixed water outlet temperature setting of the valve.

Temperature readings should be taken at the normal flow rate after allowing for the system to stabilise.

The sensing part of the thermometer probe must be fully submerged in the water that is to be tested.

Any TMV that has been adjusted or serviced must be re-commissioned and re-tested in accordance with the manufacturers' instructions.

In-service tests

Purpose

The purpose of in-service tests is to regularly monitor and record the performance of the thermostatic mixing valve. Deterioration in performance can indicate the need for service work on the valve and/ or the water supplies.

Procedure

1. Carry out the procedure 2. (a) to (e) on page 39 using the same measuring equipment, or equipment to the same specifications.
2. If the mixed water temperature has changed significantly from the previous test results (e.g. > 1 K), record the change and before re-adjusting the mixed water temperature check:
 - a) that any in-line or integral strainers are clean
 - b) any in-line or integral check valves or other anti-backsiphonage devices are in good working order
 - c) any isolating valves are fully open
3. With an acceptable mixed water temperature, complete the procedure 2. (a) to (e) on page 39.
4. If at step 2. (e) on page 39 the final mixed water temperature is greater than the values in Table A and / or the maximum temperature exceeds the corresponding value from the previous test results by more than about 2 K, the need for service work is indicated.

NOTE: In-service tests should be carried out with a frequency which identifies a need for service work before an unsafe water temperature can result. In the absence of any other instruction or guidance, the procedure described in „Frequency of in-service tests“ may be used.

Frequency of in-service tests TMV3 *

General

In the absence of any other instruction or guidance on the means of determining the appropriate frequency of in-service testing, the following procedure may be used:

1. 6 to 8 weeks after commissioning carry out the tests given in 2. on page 39.
2. 12 to 15 weeks after commissioning carry out the tests given in 2. on page 39.
3. Depending on the results of 1. and 4. several possibilities exist:
 - a) If no significant changes (e.g. < 1 K) in mixed water temperatures are recorded between commissioning and 1., or between commissioning and 4. the next in-service test can be deferred to 24 to 28 weeks after commissioning.
 - b) If small changes (e.g. 1 to 2 K) in mixed water temperatures are recorded in only one of these periods, necessitating adjustment of the mixed water temperature, then the next in-service test can be deferred to 24 to 28 weeks after commissioning.
 - c) If small changes (e.g. 1 to 2 K) in mixed water temperatures are recorded in both of these periods, necessitating adjustment of the mixed water temperature, then the next in-service test should be carried out at 18 to 21 weeks after commissioning.
 - d) If significant changes (e.g. > 2 K) in mixed water temperatures are recorded in either of these periods, necessitating service work, then the next in-service test should be carried out at 18 to 21 weeks after commissioning.
4. The general principle to be observed after the first 2 or 3 in-service tests is that the intervals of future tests should be set to those which previous tests have shown can be achieved with no more than a small change in mixed water temperature.

***TMV2: The frequency of performing the in-service tests is 1 year maximum.**

Thermostatic Adjustment

Temperature Limitation

The temperature is limited by the safety stop to 40°C. If a higher temperature is required, it is possible to over ride the safety stop by depressing the safety button.

NB. It is recommended that for private domestic use the maximum mixed water temperature be set at the following factory set values:

Shower Mixer 43°C

Bath/Shower 43°C

Temperatures can be set by following the procedures on page 32. This ensures that after correct installation the outlet temperature of the water can never exceed 43°C.

To guarantee a smooth running of the thermostatic element, it is necessary from time to time to turn the thermostat from total hot to total cold. The thermostatic mixer valve should be checked annually by a qualified person to ensure correct operation.

The mixer is fitted with check valves (page 36 pos. 96737000) and filters (page 36 pos 96922000 and 98282000). If the water flow drops the filters need to be cleaned. For that purpose please follow the steps 1 - 6 on page 33.

Calibrating Thermostat

If the temperature reading is different to the showering temperature, follow the steps 1 - 6 on page 32.

Technical Hotline

0 870 7701975

E-mail

Technical@hansgrohe.co.uk

hansgrohe

Hansgrohe · Auestraße 5 – 9 · D-77761 Schiltach · Telefon +49 (0) 78 36/51-1282 · Telefax +49 (0) 7836/511440
E-Mail: info@hansgrohe.com · Internet: www.hansgrohe.com

09/2014
9.02455.01